



FRV Services Australia Pty Ltd (FRV) is seeking approval for the development of a large scale, grid-connected solar farm located approximately 50km North-East of Emerald in Central Qld.

The generation of electricity from solar energy provides a clean, renewable alternative to fossil fuel-based electricity generation such as coal and gas-fired power stations. The proposed solar farm will help protect the environment because it doesn't produce greenhouse gas emissions when generating electricity.

The proposed Lilyvale Solar Farm development will utilise solar photovoltaic (PV) technology. With no noise or dust generation, no bright lights and very low traffic movements during operation, PV plants are relatively unobtrusive.

Project details

This project would comprise the construction and operation of a grid-connected solar farm using solar PV modules similar to those used on houses. The final design will determine the plant configuration, layout and specific equipment to be used, as well as the solar farm's electricity generating capacity.

While a final investment decision has not yet been made, it is envisaged that construction could commence sometime in 2016 to 2017 and would take between 12 to 18 months.

It is currently intended to utilise a tracking system where the PV panels rotate from east to west, following the sun across the sky, maximising the electricity production. The height of the structures including the PV modules would be no more than approximately 3m from ground level.

Inverters that are typically housed in shipping container sized structures would be

used to convert the direct current electricity generated by the PV modules into alternating current. A transformer would be installed to step up the voltage to a level suitable for injection into the national electricity grid.

It is proposed that a new electricity transmission line (ETL) would connect the solar farm to the existing Lilyvale substation.

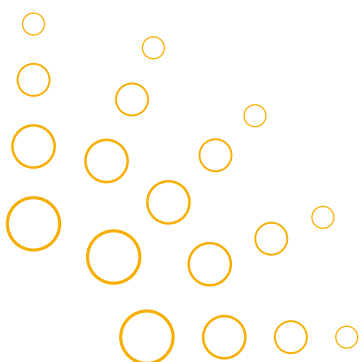
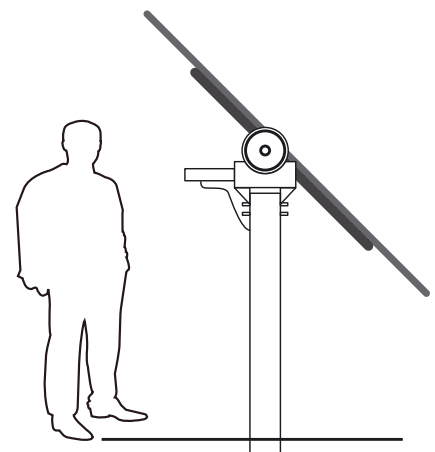

About FRV

FRV Services Australia Pty Ltd is a subsidiary of the global solar power developer Fotowatio Renewable Ventures, a company based in Spain. FRV is a globally leading large scale solar power plant developer, with experience dating back to 2006. FRV has successfully developed around 500MW of solar plants using the same or similar technology to that proposed for the Lilyvale project.

FRV has had a presence in Australia since 2010. FRV's track record of achievements in Australia includes the 20MW Royalla Solar Farm in the ACT, which is fully operating since August 2014, and the 56MW Moree Solar Farm in NSW, which is under construction and expected to be completed by 2016.

Location

The site for the proposed Lilyvale Solar Farm project is an area of approximately 400ha currently used for cattle grazing. The site is located about 10km from the township of Tieri, in the Central Highlands Region of Queensland. The nearest city is Emerald. Coal mining and agriculture are the dominant industries in the region.

The choice of location for the solar farm is driven by two main factors. This location has among the highest levels of solar irradiation in Australia and is well located to export the electricity into the national electricity grid via the existing Lilyvale substation.

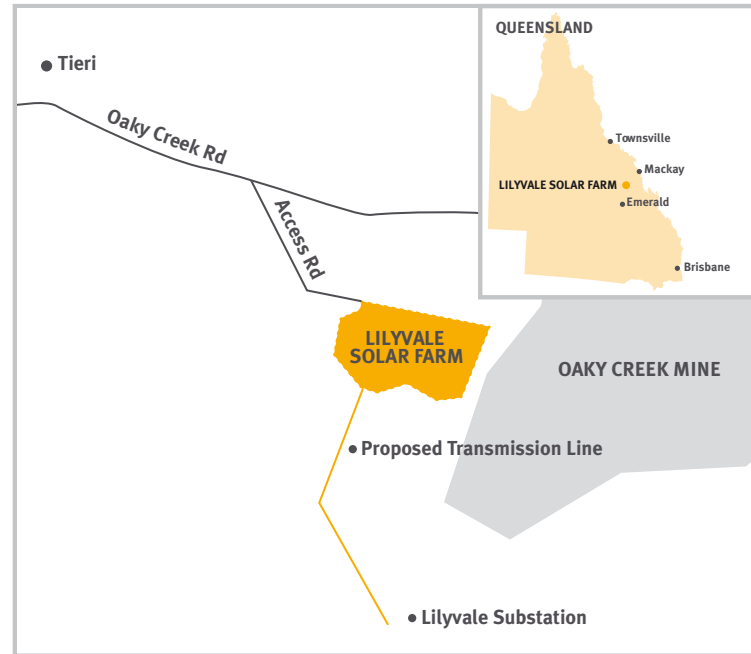

Planning and environmental considerations

FRV have engaged URS Australia as its expert consultants to assist with the project approvals, including the development application to the Central Highlands Regional Council and the referral to the Australian Department of the Environment under the Environmental Protection, Biodiversity and Conservation (EPBC) Act. Both the application and referral were lodged in December 2014.

Economic benefits

The development of a large scale solar energy project such as this would represent a positive diversification of the local economy, creating up to 200 jobs during construction and a small number of jobs during operation. There would be the opportunity for local workers to participate in the civil and/or electrical works associated with the project, as well as indirect opportunities for a range of local businesses, contractors and suppliers – e.g. accommodation providers, fuel supply, groceries and restaurants.

Community Consultation

As a developer of solar farms, FRV is committed to being a valued member of the local community. An important part of this is appropriate community consultation during the development phase, construction phase and during operation. The community has the opportunity to comment on the proposal as part of the EPBC referral and during the Council's consideration of the development application. Any member of the community is welcome to make a submission to either of these processes. In addition, FRV will engage directly with the community as the development progresses.

If you would like to receive further information about the project or provide feedback to FRV please get in touch with us via email: lilyvalesolarfarm@frv.com or www.lilyvalesolarfarm.com.au

